

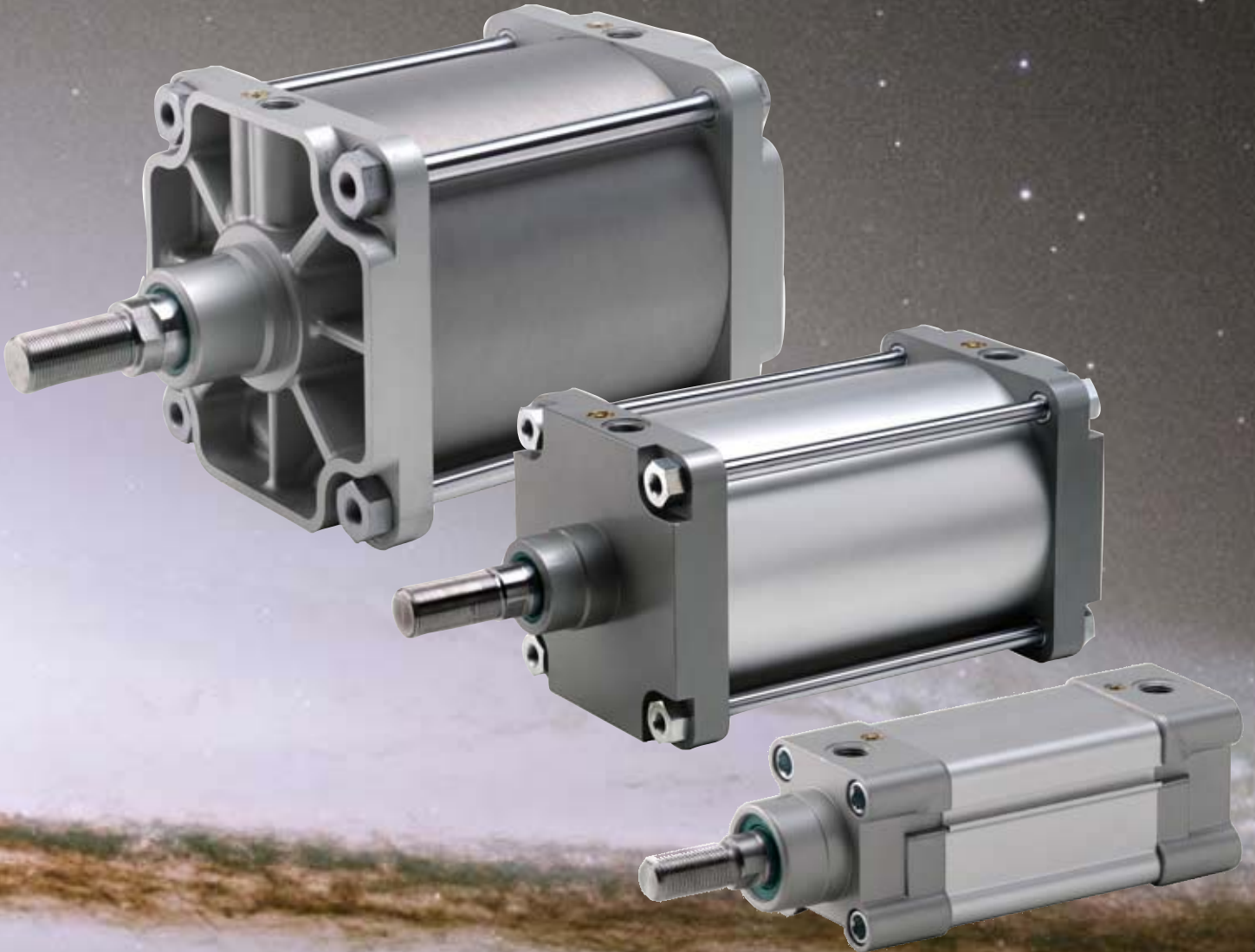

# STARCYL CYLINDERS



## ISOMETRIC SERIES

AIR CYLINDER ISO/VDMA

VDMA 24562, DIN/ISO 6431 & ISO15552



[WWW.STARCYL.COM](http://WWW.STARCYL.COM)

## AVAILABLE MODELS

STMM	STARCYL MINIMETRIC
<b>STMI</b>	<b>STARCYL ISOMETRIC</b>
STMC	STARCYL METRICOMPAC

## AVAILABLE VERSIONS

DA	DOUBLE ACTING
DR	DOUBLE ACTING - DOUBLE ROD END

## AVAILABLE OPTIONS

#2	MALE ROD END
#4	FEMALE ROD END
CU	CUSHIONED
CN	NON CUSHION
MA	MAGNETIC PISTON
RS	STAINLESS STEEL ROD (standard on MiniMetric and MetriCompact)
RE	ROD EXTENSION (Must specify length)
SS	ALL STAINLESS STEEL CYLINDER (303/304) (head, cap, tube, tie rods, rod, ...)
ST	TIE ROD CYLINDER FROM 32 TO 125 MM

## HOW TO ORDER

MODEL	STMI
VERSION	DA
BORE	32
STROKE	50
OPTION	CUMA
	<b>STMIDA-32X50-CUMA</b>
<i>isometric double acting, 32mm bore x 50 mm stroke, cushion both ends, magnetic piston sensor ready</i>	

### Conversion Table:

UNITS	kPa	bar	kg/cm <sup>2</sup>	psi
kPa	1	0.01	0.0102	0.145
bar	100	1	1.02	14.5
kg/cm <sup>2</sup>	98	0.098	1	14.2
psi	6.9	0.069	0.7	1



DIN ISO 15552 CYLINDERS - PROFILED Ø32-125MM

4

DOUBLE ACTING CUSHION OR NOT

5

DOUBLE ACTING DOUBLE ROD CUSHION OR NOT

6

MOUNTING ACCESSORIES

8



**160 & 200 mm bore**

DIN ISO 15552 CYLINDERS Ø160-320MM

16

DOUBLE ACTING

17

DOUBLE ACTING DOUBLE ROD END

18

MOUNTING ACCESSORIES

20



**250 & 320 mm bore**



SENSORS

26



SENSORS CABLES

27

# ISOMETRIC STMI SERIES



- END CAPS :** DIE-CASTED ALUMINUM
- TUBE :** ANODIZED ALUMINUM
- SEALS :** POLYURETHANE + NBR
- BUSHING :** SINTERED BRONZE
- PISTON ROD :** CHROMIUM COATED STEEL \*\*\*

\*\*\*All cylinders are available also with AISI 304 stainless steel piston rod. To order add "I" to the standard code number.



Cylinders with tie rods design are available



All stainless steel cylinders design are available (303)

WORKING PRESSURE	TEMPERATURE	WORKING FLUID
MAX 10 BAR	-20°C +80°C WITH DRY AIR	FILTERED AND LUBRICATED AIR OR NONE

## A AVAILABLE

"-CU" : cushion both ends; "-CN" : None cushion;  
"-MA" : Magnetic piston; "-SS" : Stainless steel rod

## STANDARD STRO ES

Ø mm	10	25	40	50	80	100	125	160	200	250	300	320	400	500
□	□	□	□	□	□	□	□	□	□	□	□	□	□	□
□	□	□	□	□	□	□	□	□	□	□	□	□	□	□
□	□	□	□	□	□	□	□	□	□	□	□	□	□	□
□	□	□	□	□	□	□	□	□	□	□	□	□	□	□
□	□	□	□	□	□	□	□	□	□	□	□	□	□	□
□	□	□	□	□	□	□	□	□	□	□	□	□	□	□
□	□	□	□	□	□	□	□	□	□	□	□	□	□	□
□	□	□	□	□	□	□	□	□	□	□	□	□	□	□
□	□	□	□	□	□	□	□	□	□	□	□	□	□	□

DOUBLE ACTING

# DA: DOUBLE ACTING



STMIDA-Øx...-CN

STMIDA-Øx...-CU

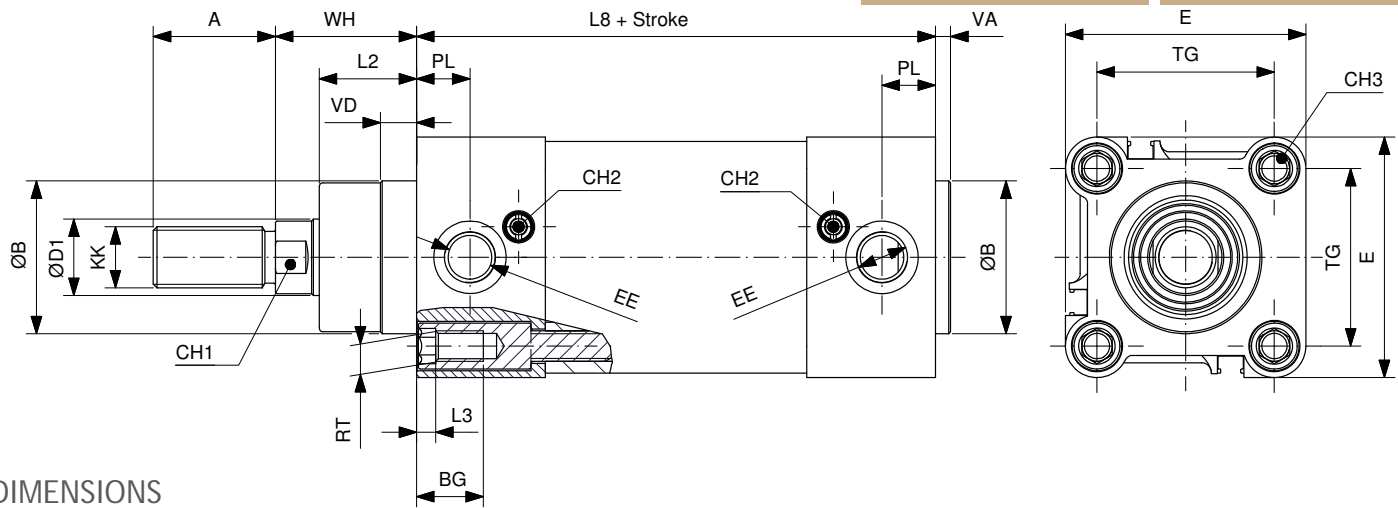

## DIMENSIONS

Ømm	ØD1	KK	A	ØB	VD	VA	L2	RT	BG	L3	TG	EE	PL	WH	L8	E	CH1	CH2	CH3
32	12	M10x1.25	22	30	9.5	4	18	M6	16.5	5	32.5	1/8"G	12.5	26	94	47	10	2.5	6
40	16	M12x1.25	24	35	9.5	4	22	M6	16.5	5	38	1/4"G	14	30	105	54	13	2.5	6
50	20	M16x1.5	32	40	9.5	4	25.5	M8	17.5	5	46.5	1/4"G	14	37	106	63	17	2.5	8
63	20	M16x1.5	32	45	9.5	4	25	M8	17.5	5	56.5	3/8"G	16.5	37	121	74	17	2.5	8
80	25	M20x1.5	40	45	10	4	35	M10	17.5	5	72	3/8"G	17	46	128	93.5	22	4	6
100	25	M20x1.5	40	55	10	4	38	M10	17.5	5	89	1/2"G	18	51	138	110	22	4	6
125	32	M27x2	54	60	11	6	46	M12	20.5	5	110	1/2"G	18	65	160	137.5	27	4	8

US ULL ORCES 6 BAR

Ø mm	US ORCE N	ULL ORCE N
32	458	394
40	716	601
50	1180	939
63	1775	1596
80	2863	2583
100	4474	4194
125	6991	6532

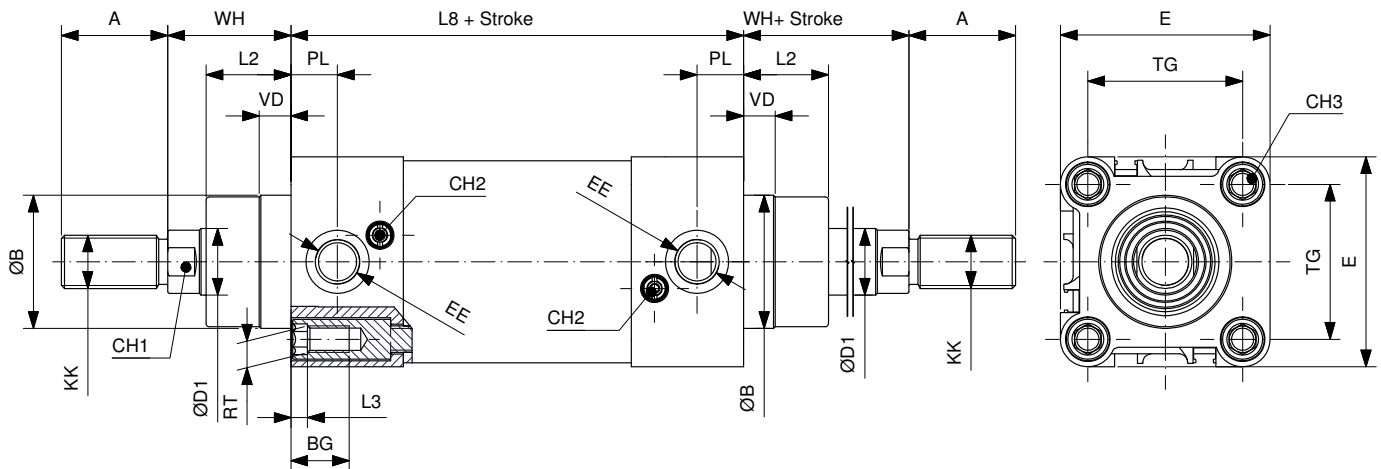

**DIMENSIONS**

Ømm	ØD1	KK	A	ØB	VD	L2	RT	BG	L3	TG	EE	PL	WH	L8	E	CH1	CH2	CH3
32	12	M10x1.25	22	30	9.5	18	M6	16.5	5	32.5	1/8"G	12.5	26	94	47	10	2.5	6
40	16	M12x1.25	24	35	9.5	22	M6	16.5	5	38	1/4"G	14	30	105	54	13	2.5	6
50	20	M16x1.5	32	40	9.5	25.5	M8	17.5	5	46.5	1/4"G	14	37	106	63	17	2.5	8
63	20	M16x1.5	32	45	9.5	25	M8	17.5	5	56.5	3/8"G	16.5	37	121	74	17	2.5	8
80	25	M20x1.5	40	45	10	35	M10	17.5	-	72	3/8"G	17	46	128	93.5	22	4	6
100	25	M20x1.5	40	55	10	38	M10	17.5	-	89	1/2"G	18	51	138	110	22	4	6
125	32	M27x2	54	60	11	46	M12	20.5	-	110	1/2"G	18	65	160	137.5	27	4	8

**US ULL ORCES 6 BAR**

Ø mm	US ORCE N	ULL ORCE N
32	394	394
40	601	601
50	939	939
63	1596	1596
80	2583	2583
100	4194	4194
125	6532	6532



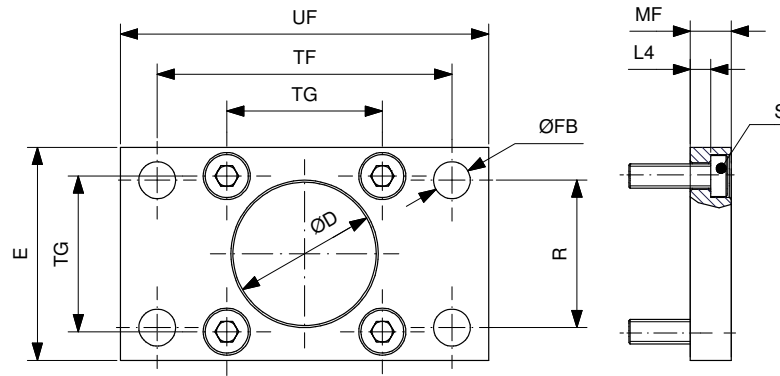

**FLANGE MOUNT (MF1-MF2)**

**MATERIAL: STEEL**

Ø mm	TG	ØD	ØFB	R	TF	L4	S	UF	E	MF	PART NUMBER
32	32.5	30	7	32	64	5	M6x20	80	45	10	STMF1-032
40	38	35	9	36	72	5	M6x20	90	52	10	STMF1-040
50	46.5	40	9	45	90	6.5	M8x20	110	65	12	STMF1-050
63	56.5	45	9	50	100	6.5	M8x20	120	75	12	STMF1-063
80	72	45	12	63	126	9	M10x25	150	95	16	STMF1-0 80
100	89	55	14	75	150	9	M10x25	170	115	16	STMF1-100
125	110	60	16	90	180	10.5	M12x25	205	140	20	STMF1-125

Note: supplied with 4 screws DIN 7984

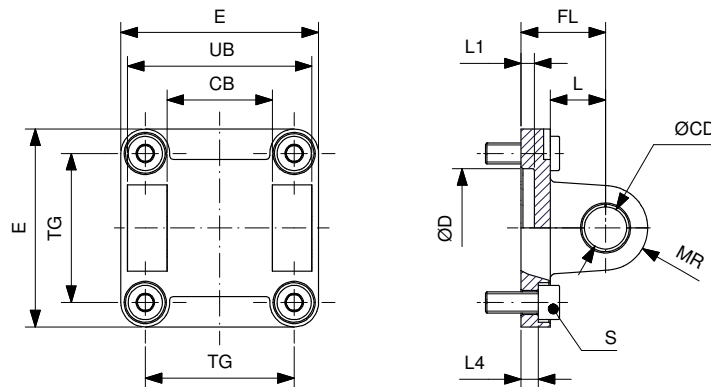

**CLEVIS MOUNT (MP2)**

**MATERIALS: ALUMINUM BODY, STEEL AND PTFE BUSHING**

Ø mm	TG	CB	UB	ØCD	FL	L	ØD	L1	L4	S	MR	E	PART NUMBER
32	32.5	26	45	10	22	13	30	5	5.5	M6x20	10	45	STMP2-032
40	38	28	52	12	25	16	35	5	5.5	M6x20	12	52	STMP2-040
50	46.5	32	60	12	27	16	40	5	6.5	M8x20	12	65	STMP2-050
63	56.5	40	70	16	32	21	45	5	6.5	M8x20	16	75	STMP2-063
80	72	50	90	16	36	22	45	5	10	M10x25	16	95	STMP2-080
100	89	60	110	20	41	27	55	5	10	M10x25	20	115	STMP2-100
125	110	70	130	25	50	30	60	7	10	M12x25	25	140	STMP2-125

Note: supplied with 4 screws DIN 912



**MOUNTING ACCESSORIES  
FOR DIN ISO 1552 CYLINDERS Ø32-125**

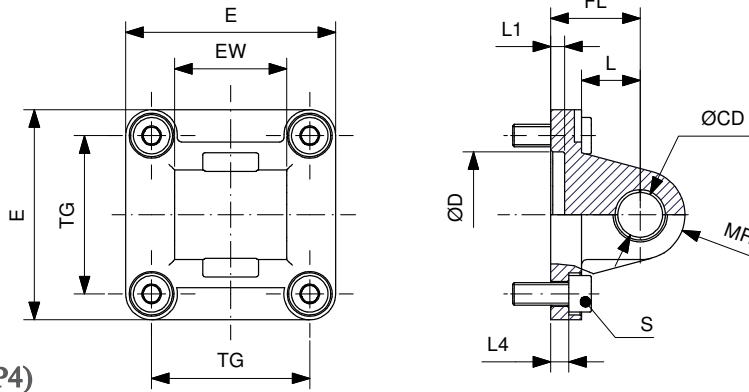

**EYE MOUNT (MP4)**

**MATERIALS: ALUMINUM BODY,  
STEEL AND PTFE BUSHINGS**

Ø mm	TG	EW	ØCD	FL	L	ØD	L1	L4	S	MR	E	PART NUMBER
32	32.5	26	10	22	13	30	5	5.5	M6x20	10	45	STMP4-032
40	38	28	12	25	16	35	5	5.5	M6x20	12	52	STMP4-040
50	46.5	32	12	27	16	40	5	6.5	M8x20	12	65	STMP4-050
63	56.5	40	16	32	21	45	5	6.5	M8x20	16	75	STMP4-063
80	72	50	16	36	22	45	5	10	M10x25	16	95	STMP4-080
100	89	60	20	41	27	55	5	10	M10x25	20	115	STMP4-100
125	110	70	25	50	30	60	7	10	M12x25	25	140	STMP4-125

Note: supplied with 4 screws DIN 912

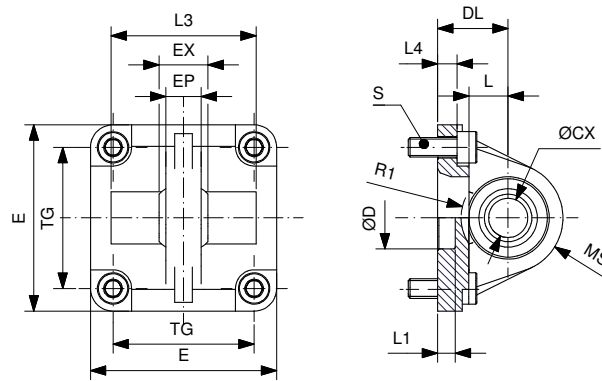

**SPHERICAL BEARING MOUNT (MP6)**

**MATERIALS: ALUMINUM BODY, STEEL AND BRONZE SPHERICAL BEARING**

Ø mm	TG	ØCX	DL	L	EX	EP	L3	R1	S	L4	ØD	L1	E	MS	PART NUMBER
32	32.5	10	22	12	14	10.5	-	-	M6x20	5.5	30	7	45	16	STMP6-032
40	38	12	25	15	16	12	-	-	M6x20	5.5	35	7	52	18	STMP6-040
50	46.5	16	27	15	21	15	51	19	M8x20	6.5	40	7	65	21	STMP6-050
63	56.5	16	32	20	21	15	-	-	M8x20	6.5	45	7	75	23	STMP6-063
80	72	20	36	20	25	18	74	24	M10x25	10	45	9	95	28	STMP6-080
100	89	20	41	25	25	18	-	-	M10x25	10	55	9	115	30	STMP6-100
125	110	30	50	30	37	25	-	-	M12x25	10	60	9	140	40	STMP6-125

Note: supplied with 4 screws DIN 912

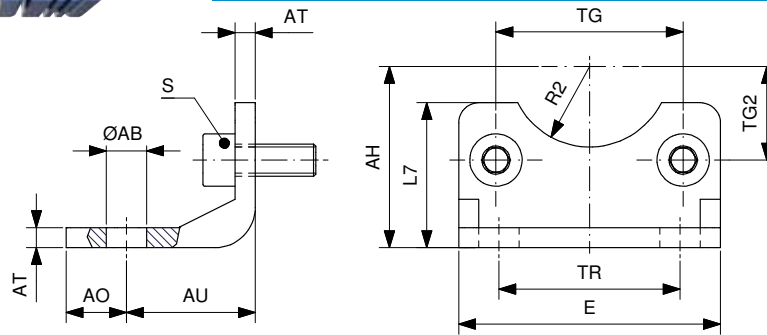

**ANGLE MOUNT (MS1)**

*MATERIAL: STEEL*

Ø mm	TG	TG2	AH	R2	ØAB	AO	AU	TR	AT	S	L7	E	PART NUMBER
32	32.5	16.25	32	15	7	11	24	32	4	M6x16	30	45	STMS1-032
40	38	19	36	17.5	10	8	28	36	4	M6x16	30	52	STMS1-040
50	46.5	23.25	45	20	10	15	32	45	5	M8x20	36	65	STMS1-050
63	56.5	28.25	50	22.5	10	13	32	50	5	M8x20	35	75	STMS1-063
80	72	36	63	22.5	12	14	41	63	6	M10x20	47	95	STMS1-080
100	89	44.5	71	27.5	14.5	16	41	75	6	M10x20	53	115	STMS1-100
125	110	55	90	30	16.5	25	45	90	8	M12x25	70	140	STMS1-125

Note: supplied with 2 screws DIN 912

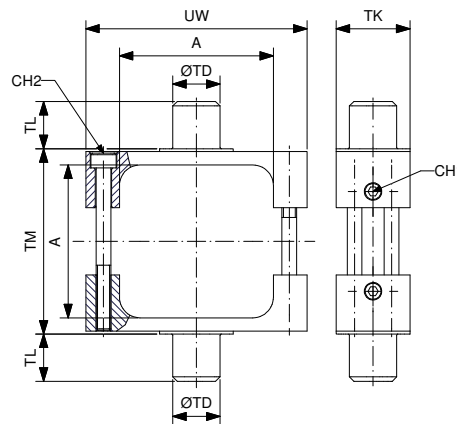

**MID TRUNNION FOR PROFILE CYLINDER (MT4)**

*MATERIAL: STEEL*

Ø mm	A	TM	TL	TK	ØTD	UW	CH1	CH2	PART NUMBER
32	45	50	11.5	25	12	65	3	3	STMT4-032
40	51.8	63	16	25	16	75	3	4	STMT4-040
50	60.7	75	16	30	16	95	3	5	STMT4-050
63	72.2	90	20	30	20	105	3	5	STMT4-063
80	91.2	110	20	30	20	130	3	5	STMT4-080
100	108.2	132	24.5	40	25	145	4	6	STMT4-100
125	135.3	160	24.5	40	25	176	4	6	STMT4-125

**MOUNTING ACCESSORIES  
FOR DIN ISO 15552 CYLINDERS Ø32-125**

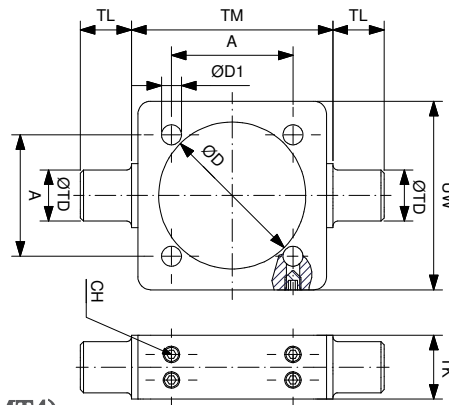

**MID TRUNNION FOR TIE RODS CYLINDERS (MT4)**

**MATERIAL: STEEL**

Ø mm	A	TM	TL	TK	ØTD	ØD	ØD1	UW	CH	PART NUMBER
32	32.5	50	12	15	12	37	6.25	46	2.5	STMT4-032T
40	38	63	16	20	16	46	6.25	59	2.5	STMT4-040T
50	46.5	75	16	20	16	56	8.25	69	3	STMT4-050T
63	56.5	90	20	25	20	69	8.25	84	3	STMT4-063T
80	72	110	20	25	20	87	10.25	102	4	STMT4-080T
100	89	132	25	30	25	107	10.25	125	4	STMT4-100T
125	110	160	25	32	25	133	12.25	155	5	STMT4-125T

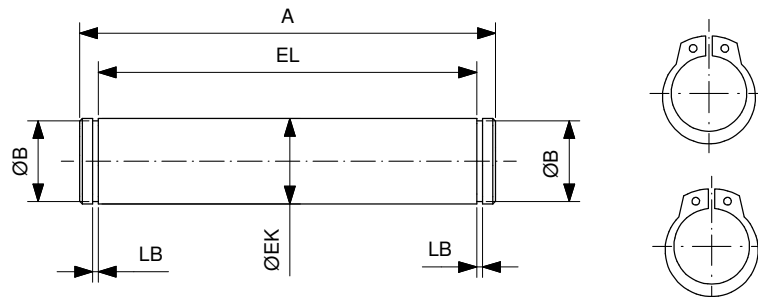

**PIVOT FOR FEMALE CLEVIS (AA4)**

**MATERIAL: STEEL**

Ø mm	ØEK	EL	ØB	LB	A	PART NUMBER
32	10	46	9.6	1.1	53	STMP-032-010
40	12	53	11.5	1.1	60	STMP-040-012
50	12	61	11.5	1.1	68	STMP-050-012
63	16	71	15.2	1.1	78	STMP-063-016
80	16	91	15.2	1.1	98	STMP-080-016
100	20	111	19	1.3	118	STMP-100-020
125	25	132	23.9	1.3	139	STMP-125-025

Note: supplied with snap ring

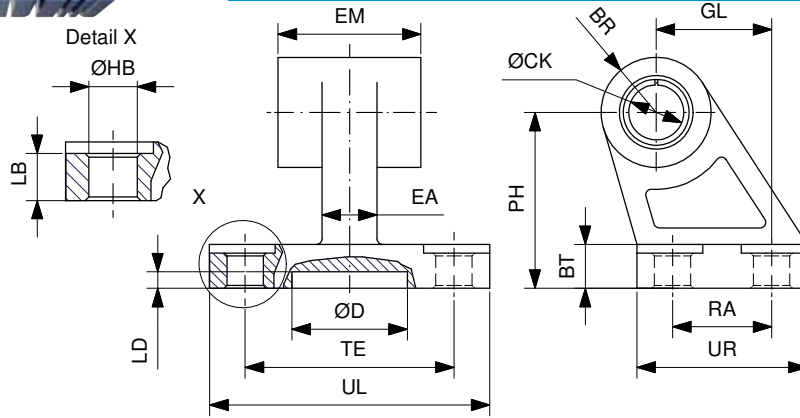

**SQUARE JOINT (AB7)**

**MATERIALS: ALUMINUM BODY, STEEL AND PTFE BUSHINGS**

Ø mm	CK	EM	BR	PH	GL	ØHB	LB	BT	TE	RA	ØD	LD	UL	UR	EA	PART NUMBER
32	10	26	10	32	21	6.6	6.4	8	38	18	21	3	51	31	10	SMART-032
40	12	28	11	36	24	6.6	8.4	10	41	22	21	3	54	35	15	SMART-040
50	12	32	13	45	33	9	10.4	12	50	30	21	3	65	45	16	SMART-050
63	16	40	15	50	37	9	12.4	14	52	35	21	3	67	50	16	SMART-063
80	16	50	15	63	47	11	11.5	14	66	40	21	3	86	60	20	SMART-080
100	20	60	19	71	55	11	14.5	17	76	50	11	3	96	70	20	SMART-100
125	25	70	22.5	90	70	14	16.8	20	94	60	21	3	124	90	30	SMART-125

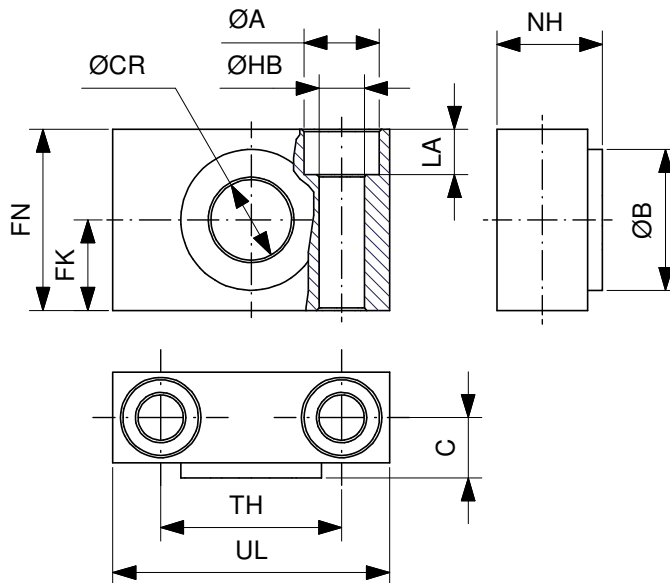

**TRUNNION BRACKET (AT4)**

**MATERIALS: ALUMINUM BODY AND BRONZE BUSHING**

Ø mm	ØCR	FN	FK	ØHB	ØA	LA	TH	C	UL	NH	ØB	PART NUMBER
32	12	30	15	6.6	11	7	32	10.5	46	18	22	STMITB-032/000
40-50	16	36	18	9	15	9	36	12	55	21	28	STMITB-040/050
63-80	20	40	20	11	18	11	42	13	65	23	32	STMITB-063/080
100-125	25	50	25	14	20	13	50	16	75	28.5	39	STMITB-100/125

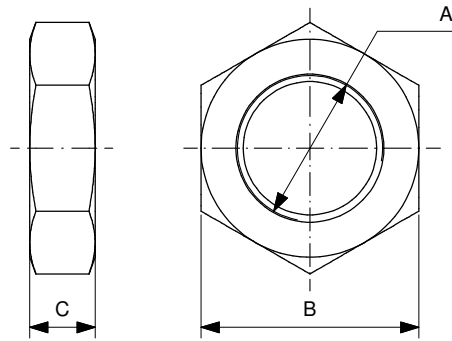

**JAM NUT (ROD)**

**MATERIAL: STEEL**

Ø mm	A	B	C	PART NUMBER
32	M10x1.25	17	6	STJN-M10X1.25C06
40	M12x1.25	19	7	STJN-M12X1.25C07
50-63	M16X1.5	24	8	STJN-M16X1.50C08
80-100	M20x1.5	30	9	STJN-M20X1.50C09
125	M27x2	41	12	STJN-M27X2.00C12

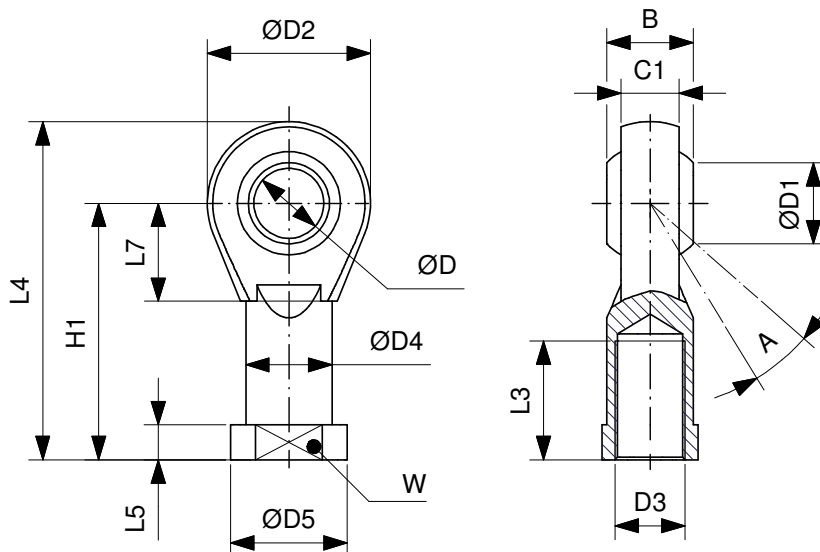

**MATERIAL: STEEL  
STAINLESS STEEL AVAILABLE**

**SELF-LUBRICATING SPHERICAL ROD ENDS**

D3	W	L3	A	ØD	ØD1	C1	B	ØD4	ØD5	L5	L7	H1	L4	ØD2	PART NUMBER
M10x1.25	17	20	13°	10	12.9	10.5	14	15	19	6.5	15	43	57	28	STMSR-M10X1.25
M12x1.25	19	22	13°	12	15.4	12	16	17.5	22	6.5	17	50	66	32	STMSR-M12X1.25
M16x1.5	22	28	15°	16	19.3	15	21	22	27	8	23	64	85	42	STMSR-M16.1.50
M20x1.5	30	33	14°	20	24.3	18	25	27.5	34	10	27	77	102	50	STMSR-M20X1.50
M27x2	41	51	17°	30	34.8	25	37	40	50	15	36	110	145	70	STMSR-M27X2.00

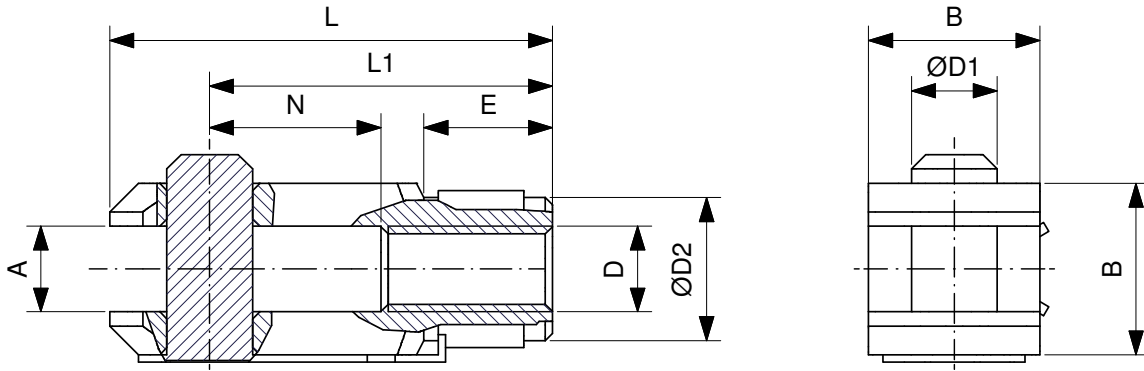

**CLEVIS WITH LOCK PIN**

**MATERIAL: STEEL**

D	A	B	ØD1	N	L1	L	E	ØD2	PART NUMBER
M10x1.25	10	20	10	20	40	52	15	18	STMRC-M10X1.25
M12x1.25	12	24	12	24	48	62	18	20	STMRC-M12X1.25
M16x1.5	16	32	16	32	64	83	24	26	STMRC-M16X1.50

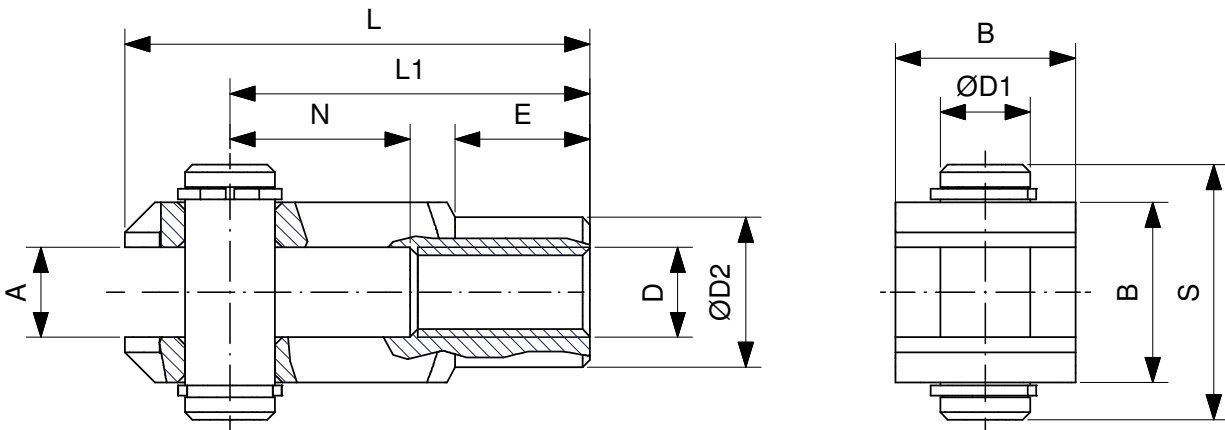

**CLEVIS WITH PIVOT PIN AND SNAP RING**

**MATERIAL: STEEL**

D	A	B	ØD1	S	N	L1	L	E	ØD2	ART NUMBER
M20x1.5	20	40	20	48	40	80	105	30	34	STMRC-M20X1.50
M27x2	30	55	30	65	54	110	148	38	48	STMRC-M27X2.00



# ISOMETRIC

## STMI SERIES



**END CAPS :** ALUMINUM  
**TUBE :** ANODIZED ALUMINUM  
**SEALS :** POLYURETHANE + NBR  
**BUSHING:** SINTERED BRONZE  
**PISTON ROD:** CHROMIUM COATED STEEL  
**TIE RODS:** STEEL

**WORKING PRESSURE**  
MAX 10 BAR

**TEMPERATURE**  
-20°C +80°C WITH DRY AIR

**WORKING FLUID**  
FILTERED AND LUBRICATED AIR  
OR NONE

All cylinders are available also with 303/304 stainless piston rod.  
To order add "RS" to the standard code number.

### AVAILABLE VERSIONS

A: U AC N ; : U U N

### STANDARD STROKES

Ø mm	25	40	50	80	100	125	160	200	250	300	320	400	500
160	☒	☒	☒	☒	☒	☒	☒	☒	☒	☒	☒	☒	☒
200	☒	☒	☒	☒	☒	☒	☒	☒	☒	☒	☒	☒	☒
250	☒	☒	☒	☒	☒	☒	☒	☒	☒	☒	☒	☒	☒
320	☒	☒	☒	☒	☒	☒	☒	☒	☒	☒	☒	☒	☒

DOUBLE ACTING



# DOUBLE ACTING



STMIDA-Øx...

STMIDA-Øx...-CU

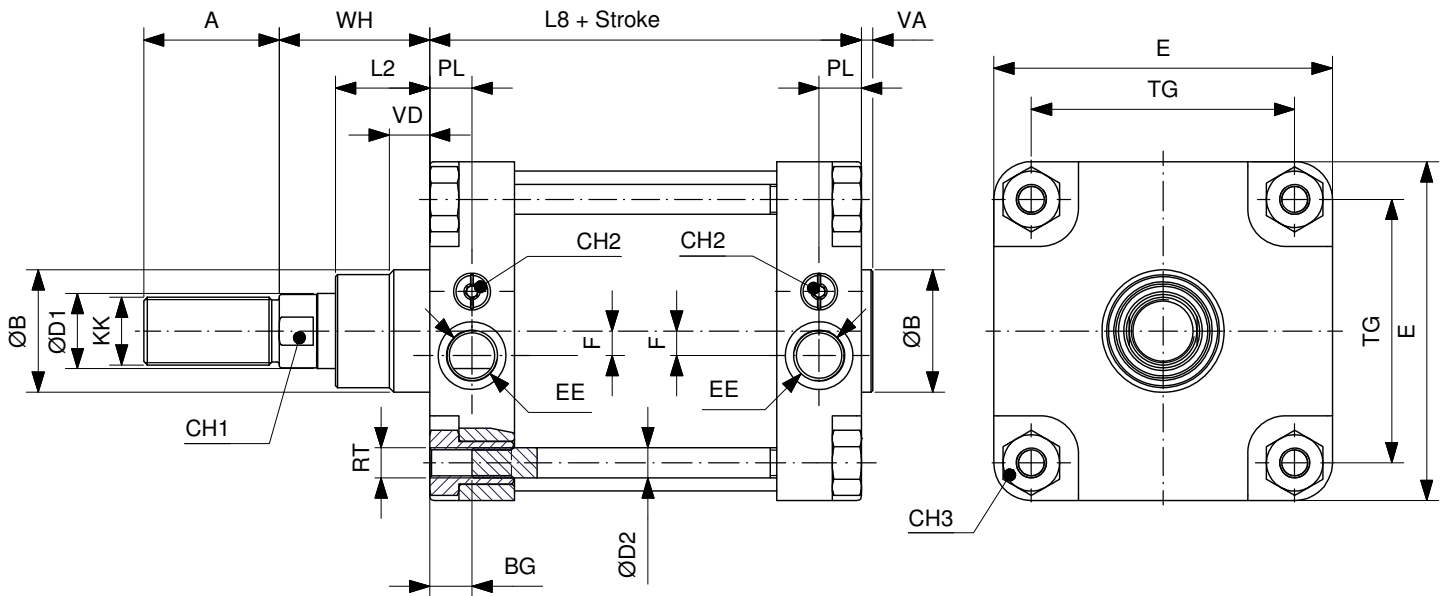

## DIMENSIONS

Ø mm	ØD1	ØD2	KK	A	ØB	VD	VA	L2	RT	BG	TG	EE	F	PL	WH	L8	E	CH1	CH2	CH3
160	40	16	M36X2	72	65	21.5	6	50	M16X2	22.5	140	3/4"G	13	22.5	80	179.5	180	36	6	30
200	40	16	M36X2	72	75	26.5	6	55	M16X2	22.5	175	3/4"G	13	22.5	95	180	220	36	6	30
250	50	20	M42X2	84	90	20	10	67	M20X2.5	25	220	1"G	15	31	105	200	268	46	6	36
320	63	25	M48X2	96	110	20	10	82	M24X3	28	270	1"G	-	31	120	220	340	55	6	46

US ULL ORCES 6 BAR

Ø mm	US ORCE N	ULL ORCE N
160	11454	10738
200	17898	17182
250	27966	26847
320	45819	44043

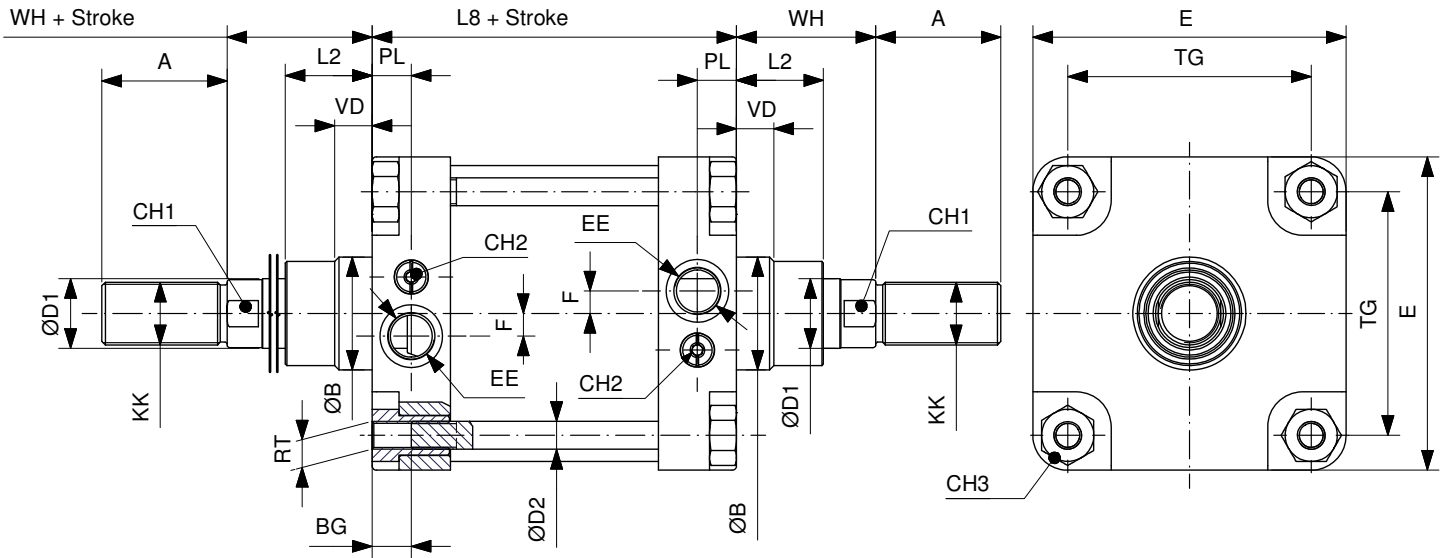

DIMENSIONS

Ømm	ØD1	ØD2	KK	A	ØB	VD	L2	RT	BG	TG	EE	F	PL	WH	L8	E	CH1	CH2	CH3
160	40	16	M36X2	72	65	21.5	50	M16X2	22.5	140	3/4"G	13	22.5	80	179.5	180	36	6	30
200	40	16	M36X2	72	75	26.5	55	M16X2	22.5	175	3/4"G	13	22.5	95	180	220	36	6	30
250	50	20	M42X2	84	90	20	67	M20X2.5	25	220	1"G	15	31	105	200	268	46	6	36
320	63	25	M48X2	96	110	20	82	M24X3	28	270	1"G	-	31	120	220	340	55	6	46

US ULL ORCES 6 BAR

Ø mm	US ORCE N	ULL ORCE N
160	10738	10738
200	17182	17182
250	26847	26847
320	44043	44043



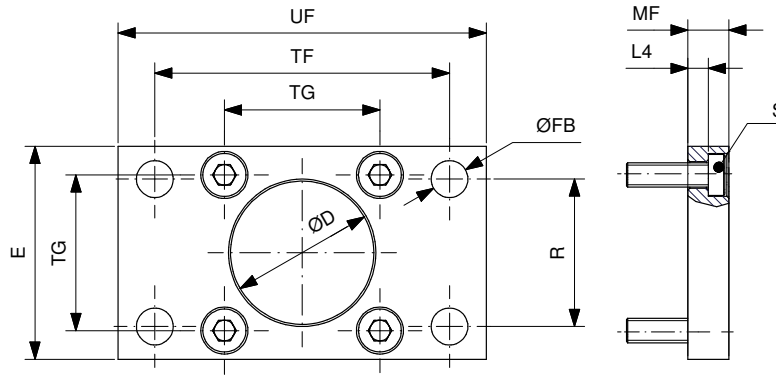

**FLANGE (MF1-MF2)** (not available in 250 & 320 mm bore)

**MATERIAL: STEEL**

Ø mm	TG	ØD	ØFB	R	TF	L4	S	UF	E	MF	PART NUMBER
160	140	65	18	115	230	9.5	M16x30	260	180	20	STMF1-160
200	175	75	22	135	270	12.5	M16x30	300	220	25	STMF1-200

Note: supplied with 4 screws DIN 7984

## 160 & 200 MM BORE

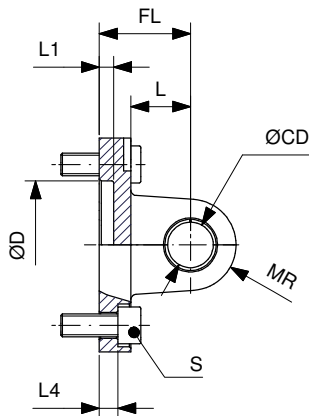
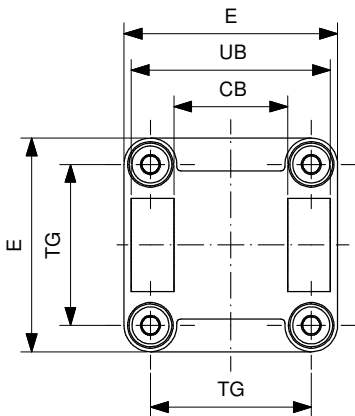

## 250 & 320 MM BORE

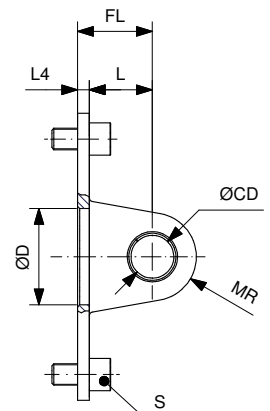
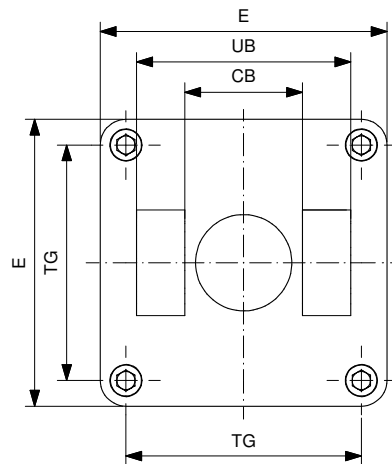

## CLEVIS MOUNT (MP2)

**MATERIALS: ALUMINUM BODY, STEEL AND PTFE BUSHINGS**

Ø mm	TG	CB	UB	ØCD	FL	L	ØD	L1	L4	S	MR	E	PART NUMBER
160	140	90	170	30	55	35	65	7	10	M16x30	25	160	STMP2-160
200	175	90	170	30	60	35	75	7	11	M16x30	25	220	STMP2-200
250	220	110	200	40	70	59	90	11	-	M20x35	41	268	STMP2-250
320	270	120	220	45	80	65	110	15	-	M24x40	45	340	STMP2-320

Note: supplied with 4 screws DIN 912

## 160 & 200 MM BORE

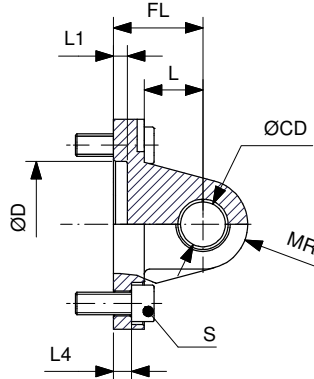
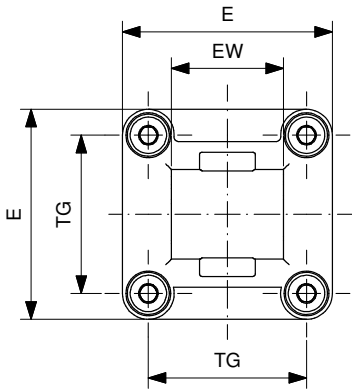

## 250 & 320 MM BORE

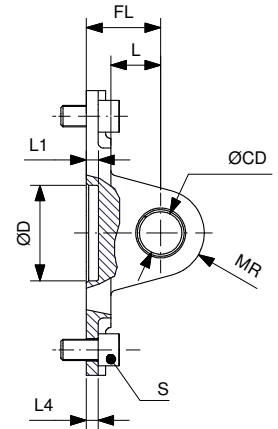
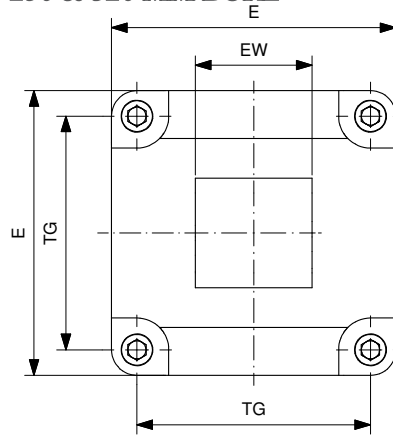

### EYE MOUNT (MP4)

MATERIALS: ALUMINUM BODY, STEEL AND PTFE BUSHING

Ø mm	TG	EW	ØCD	FL	L	ØD	L1	L4	S	MR	E	PART NUMBER
160	140	90	30	55	35	65	7	10	M16x30	25	180	STMP4-160
200	175	90	30	60	35	75	7	11	M16x30	25	220	STMP4-200
250	220	110	40	70	47	90	11.5	11	M20x35	41	268	STMP4-250
320	270	120	45	80	52	110	11.5	15	M24x40	45	340	STMP4-320

Note: supplied with 4 screws DIN 912

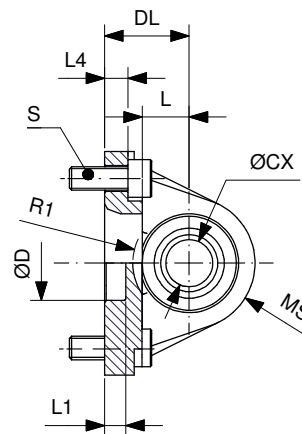
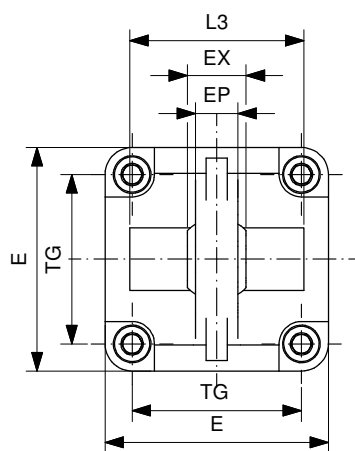

### SPHERICAL BEARING MOUNT (MP6)

MATERIALS: ALUMINUM BODY, STEEL AND BRONZE SPHERICAL BEARING

Ø mm	TG	CX	DL	L	EX	EP	L3	R1	S	L4	ØD	L1	E	MS	ART NUMBER
160	140	35	55	35	43	30	-	-	M16x30	10	65	7	195	44	STMP6-160
200	175	35	60	35	43	30	-	-	M16x30	11	75	7	238	47	STMP6-200

Note: supplied with 4 screws DIN 912

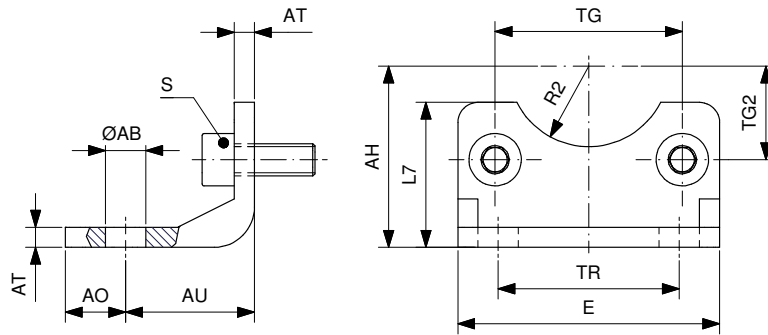

ANGLE MOUNT (MS1)

MATERIAL: STEEL

Ø mm	TG	TG2	AH	R2	ØAB	AO	AU	TR	AT	S	L7	E	PART NUMBER
160	140	70	115	32.5	18.5	15	60	115	10	M16x30	100	180	STMS1-160
200	175	87.5	135	37.5	24	30	70	135	12	M16x30	109	220	STMS1-200

Note: supplied with 2 screws DIN 912

160 & 200 MM BORE

250 & 320 MM BORE

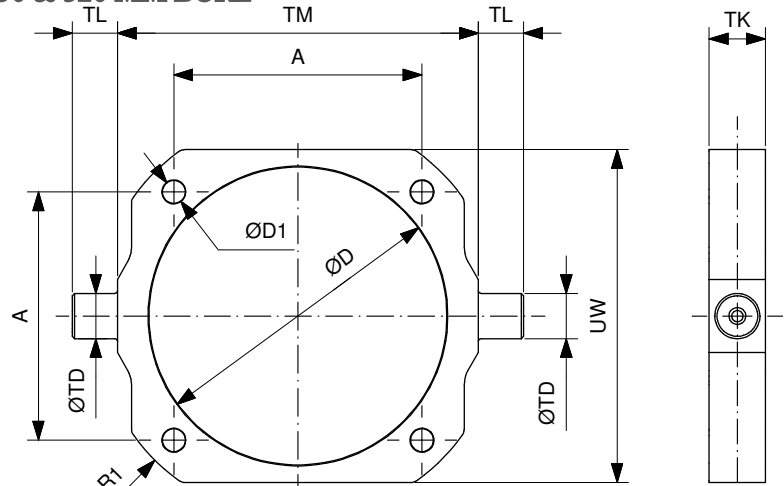
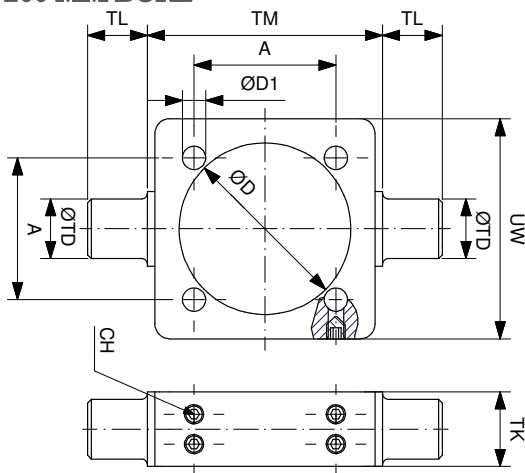

MID TRUNNION (MT4)

MATERIAL: STEEL

Ø mm	A	TM	TL	TK	ØTD	ØD	ØD1	UW	R1	NUT (*)	PART NUMBER
160	140	200	32	40	32	170	16.25	190	-	M16x2	STMT4-160T
200	175	250	32	40	32	211	16.25	240	-	M16x2	STMT4-200T
250	220	320	40	50	40	264	20.25	295	180	M20x2,5	STMT4-250T
320	270	400	50	70	50	338	24.25	370	220	M24x3	STMT4-320T

Note: it is possible to use the intermediate Trunnion only with cylinders equipped with threaded tie rods. The accessory is supplied with the nuts for the positioning and fixing. (\*)

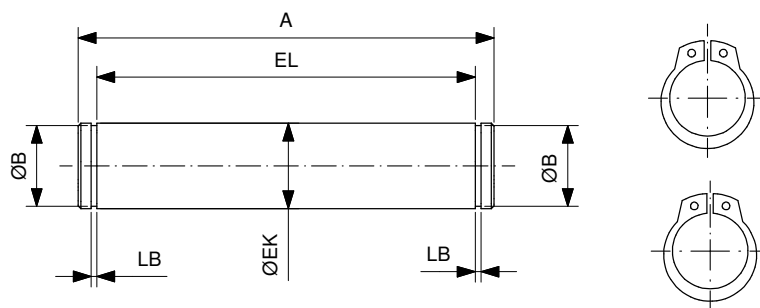

**PIVOT PIN (AAA)**

**MATERIAL: STEEL**

Ø mm	ØEK	EL	ØB	LB	A	PART NUMBER
160-200	30	172	28.6	1.6	180	STMP-160-030
250	40	202	37.5	1.85	214	STMP-250-040
320	45	222	42.5	1.85	234	STMP-320-045

Note: supplied with snap rings

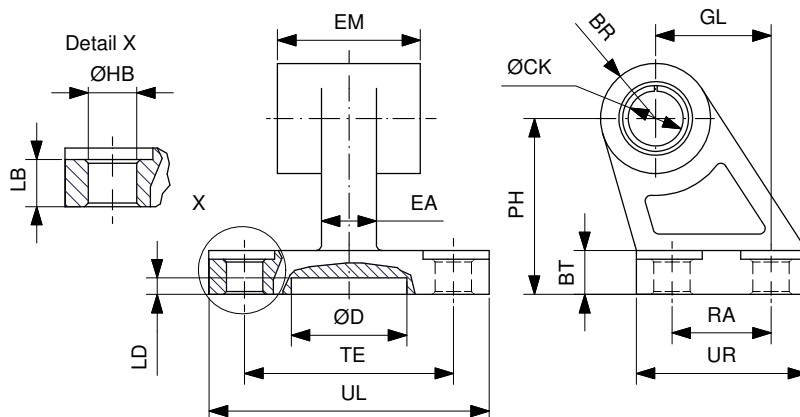

**SQUARE JOINT (AB7)**

**MATERIALS: ALUMINUM BODY, STEEL AND PTFE BUSHES**

Ø mm	ØCK	EM	BR	PH	GL	ØHB	LB	BT	TE	RA	ØD	LD	UL	UR	EA	PART NUMBER
160	30	90	31.5	115	97	14	21	25	118	88	31	5	156	126	36	SMART-160
200	30	90	31.5	135	105	18	26	30	122	90	31	5	162	130	40	SMART-200

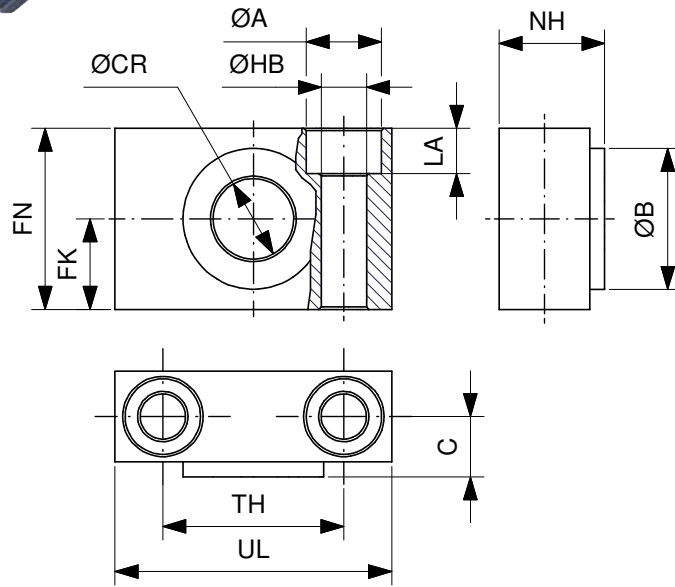

**SUPPORT FOR MID TRUNNION (AT4)**

*MATERIALS: ALUMINUM BODY & BRONZE BUSHING*

Ø mm	ØCR	FN	FK	ØHB	ØA	LA	TH	C	UL	NH	ØB	PART NUMBER
160-200	32	60	30	18	26	17	60	22.5	92	40	45	STMITB-160/200

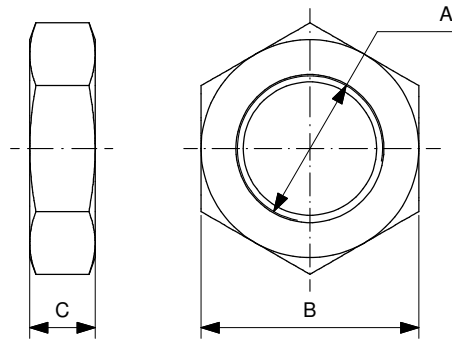

**JAM NUT**

*MATERIAL: STEEL*

Ø mm	A	B	C	PART NUMBER
160-200	M36x2	55	14	STJN-M36X2.00C14
250	M42x2	65	16	STJN-M42X2.00C16
320	M48x2	75	18	STJN-M48X2.00C18



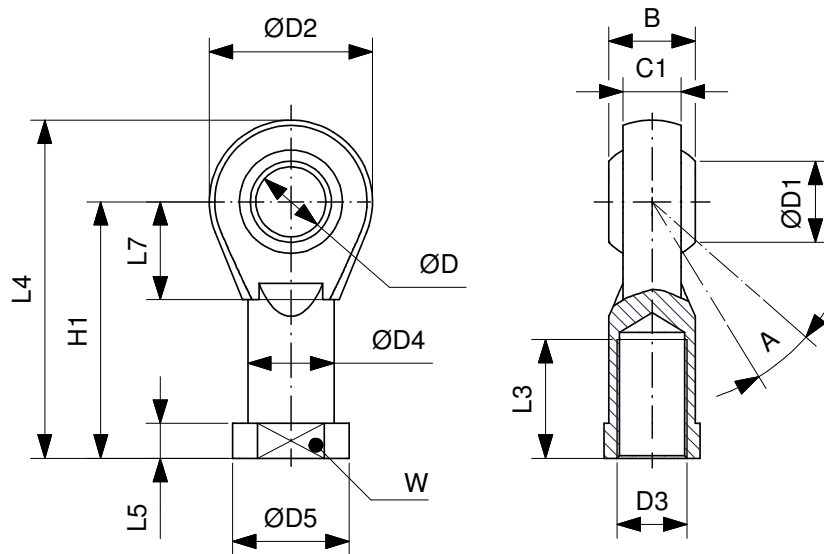

**SPHERICAL SELF-LUBRICATING ROD ENDS**

*MATERIAL: STEEL*

D3	W	L3	A	ØD	ØD1	C1	B	ØD4	ØD5	L5	L7	H1	L4	D2	PART NUMBER
M36x2	50	56	19°	35	37.7	28	43	46	58	17	41	125	165	80	STMSR-M36X2.00

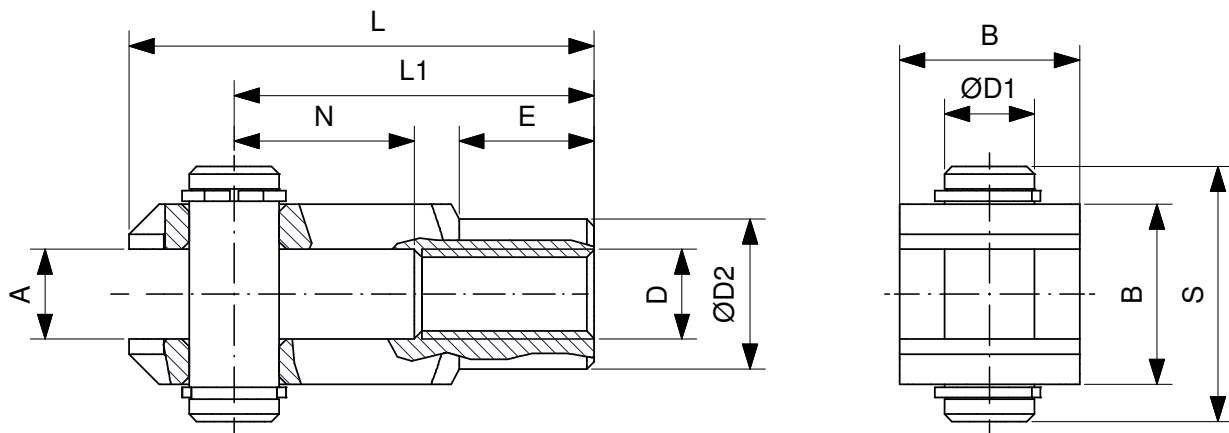

**CLEVIS WITH PIVOT**

*MATERIAL: STEEL*

D	A	B	ØD1	S	N	L1	L	E	ØD2	PART NUMBER
M36x2	35	70	35	84	72	144	188	40	60	STMRC-M36X2.00
M42x2	40	85	40	104.3	84	168	232	63.5	70	STMRC-M42X2.00
M48x2	50	96	50	117.3	96	192	265	73	82	STMRC-M48X2.00

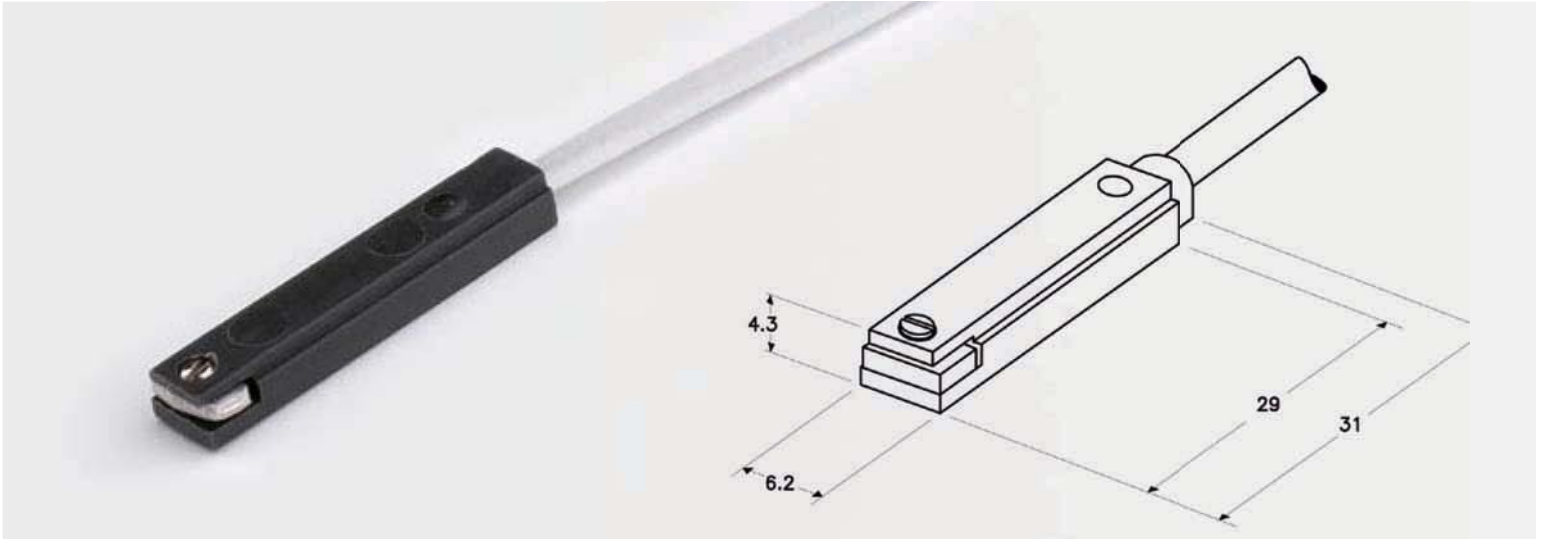

SERIE / SERIES	ZS		
S	9G10-000-002	9G10-000-031	9G10-000-032
S M	9G10-000-302	9G10-000-331	9G10-000-332
S T	Reed switch N.O.	R N N O	M N N O
	3÷30 V ac/dc		3÷30 V dc
S	0.2 A		
	6 W		
O	≤ 3 V	/	≤ 1 V
R ON	0.5 ms		0.8 μs
R O	0.1 ms		0.3 μs
N	20÷25 AT		40 Gauss (34-46) Gauss
ON-O	5÷10 AT		5÷15 Gauss
O	-10 ÷ +70 °C		
O	max 500 Hz		max 200 KHz
L	10 <sup>7</sup> imp		10 <sup>9</sup> imp
	YES		
S	YES		
E	I P 67		

M CONNECTOR

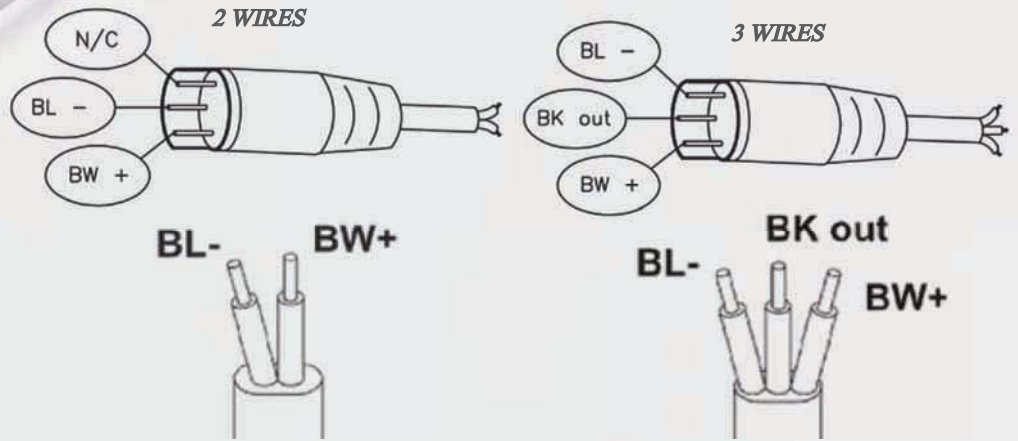

**RC08S-FOM030120 (2m length)**

**RC08S-FOM030150 (5m length)**

S	2.5 m (flying connector with cable) 0.3 m (
C	0.14 mm <sup>2</sup> / AWG 26 / (36x 0.07 mm <sup>2</sup> )
I	PVC
S	PVC ø 2.7 mm
	V2
Certification	CEI EN 60529; CEI EN 60947-5-2; CEI EN 61000-6-2; CEI EN 61000-6-3; CEI EN 55022; CEI EN 61000-4-2; CEI EN 61000-4-3 CEI EN 61000-4-4; CEI EN 65000-4-5; CEI EN 61000-4-8; CEI EN 61000-4-11; CEI EN 61000-4-6

**PROTECTION CIRCUIT FOR SWITCHES**

The switching of inductive loads made by REED produces an high voltage peak during the drop-out. In order to prevent dielectric discharges or voltaic arcs, you have to introduce a protection circuit.  
It can be:

- a R-C circuit in parallel to the switch in case of V dc supply - (Img.1)
- a diode in parallel to the load in case of V dc supply - (Img.2)
- n°2 Zener diodes in parallel to the load with V ac/dc supply - (Img.3)
- a varistor (VDR) in parallel to the load with V ac/dc supply - (Img.4)

The switching of capacitive loads or the use of cables longer than 10 meters produces current peaks during the connection. For this reason you have to introduce a protection resistance near the switch on the brown wire. Please, pay attention in garanting the minimum necessary current to the switch. (10 20 mA)

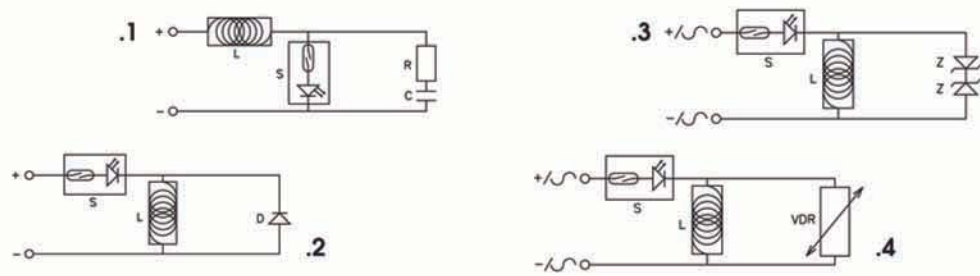



Ø mm cylinder	A	B	C	PART NUMBER
32-63	14	9	22	STMIC-032
80-100	19	12	34	STMIC-080
125	21	14	33	STMIC-125
160-200	26	18	42	STMIC-160
250	26	20.5	42	STMIC-250
320	26	25.5	42	STMIC-320

## *COVERING FOR SENSOR SLOT*



MATERIAL	COLOR	LENG T	ART NUMBER
PLASTIC	BLUE	0.5	STXLB-11

# METRICOMPAC

STMC SERIES



- END CAPS : DIE-CASTED ALUMINUM
- TUBE : ANODIZED ALUMINUM
- SEALS : POLYURETHANE + NBR
- BUSHING : SINTERED BRONZE
- PISTON ROD : 303 STAINLESS STEEL
- OTHERS : MAGNETIC PISTON AND FEMALE ROD END STANDARD

ISO 21287 COMPACT CYLINDERS Ø20-100

# MINIMETRIC

STMM SERIES - ISO 6432



- END CAPS : ANODIZED ALUMINUM
- TUBE : 304 STAINLESS STEEL
- PISTON : ALUMINUM
- SEALS : POLYURETHANE
- BUSHING : SINTERED BRONZE
- PISTON ROD : 303 STAINLESS STEEL
- READY FOR SENSORS (Magnetic Piston)

MINIMETRIC CYLINDERS Ø8-25



MINIMETRIC CYLINDERS Ø32-63



*CARTRIDGE CYLINDERS*



*TWIN ROD CYLINDERS*



*NON ROTATING SLIDE FOR CYLINDERS*



## Offer of Sale

The items described in this document are hereby offered for sale at prices to be established by STARCYL Cylinder, and its authorized distributors. This offer and its acceptance by any customer ("Buyer") shall be governed by all of the following Terms and Conditions.

Buyer's order for any item described in its document, when communicated to STARCYL cylinder, or an authorized distributor ("Seller") verbally or in writing, shall constitute acceptance of this offer.

1. **Terms and Conditions of Sale:** All descriptions, quotations, proposals, offers, acknowledgments, acceptances and sales of Seller's products are subject to and shall be governed exclusively by the terms and conditions stated herein. Buyer's acceptance of any offer to sell is limited to these terms and conditions. Any terms or conditions in addition to, or inconsistent with those stated herein, proposed by Buyer in any acceptance of an offer by Seller, are hereby objected to. No such additional, different or inconsistent terms and conditions shall become part of the contract between Buyer and Seller unless expressly accepted in writing by Seller. Seller's acceptance of any offer to purchase by Buyer is expressly conditional upon Buyer's assent to all the terms and conditions stated herein, including any terms in addition to, or inconsistent with those contained in Buyer's offer. Acceptance of Seller's products shall in all events constitute such assent.

2. **Payment:** Payment shall be made by Buyer net 30 days from the date of delivery of the items purchased hereunder. Amounts not timely paid shall bear interest at the maximum rate permitted by law for each month or portion thereof that Buyer is late in making payment. Any claims by Buyer for omissions or shortages in a shipment shall be waived unless Seller receives notice thereof within 10 days after Buyer's receipt of the shipment.

3. **Delivery:** Unless otherwise provided on the face hereof, delivery shall be made EX WORKS . Seller's plant. Regardless of the method of delivery, however, risk of loss shall pass to Buyer upon Seller's delivery to a carrier. Any delivery dates shown are approximate only and Seller shall have no liability for any delays in delivery.

4. **Warranty:** Seller warrants that the items sold hereunder shall be free from defects in material or workmanship for a period of 18 months from date of shipment to Buyer. THIS WARRANTY COMPRISES THE SOLE AND ENTIRE WARRANTY PERTAINING TO ITEMS PROVIDED HEREUNDER. SELLER MAKES NO OTHER WARRANTY, GUARANTEE, OR REPRESENTATION OF ANY KIND WHATSOEVER. ALL OTHER WARRANTIES, INCLUDING BUT NOT LIMITED TO, MERCHANTABILITY AND FITNESS FOR PURPOSE, WHETHER EXPRESS, IMPLIED, OR ARISING BY OPERATION OF LAW, TRADE USAGE, OR COURSE OF DEALING ARE HEREBY DISCLAIMED. NOTWITHSTANDING THE FOREGOING, THERE ARE NO WARRANTIES WHATSOEVER ON ITEMS BUILT OR ACQUIRED WHOLLY OR PARTIALLY, TO BUYER'S DESIGNS OR SPECIFICATIONS.

5. **Limitation of Remedy:** SELLER'S LIABILITY ARISING FROM OR IN ANY WAY CONNECTED WITH THE ITEMS SOLD OR THIS CONTRACT SHALL BE LIMITED EXCLUSIVELY TO REPAIR OR REPLACEMENT OF THE ITEMS SOLD OR REFUND OF THE PURCHASE PRICE PAID BY BUYER, AT SELLER'S SOLE OPTION. IN NO EVENT SHALL SELLER BE LIABLE FOR ANY INCIDENTAL, CONSEQUENTIAL OR SPECIAL DAMAGES OF ANY KIND OR NATURE WHATSOEVER, INCLUDING BUT NOT LIMITED TO LOST PROFITS ARISING FROM OR IN ANY WAY CONNECTED WITH THIS AGREEMENT OR ITEMS SOLD HEREUNDER, WHETHER ALLEGED TO ARISE FROM BREACH OF CONTRACT, EXPRESS OR IMPLIED WARRANTY, OR IN TORT, INCLUDING WITHOUT LIMITATION, NEGLIGENCE, FAILURE TO WARN OR STRICT LIABILITY.

6. **Changes, Reschedules and Cancellations:** Buyer may request to modify the designs or specifications for the items sold hereunder as well as the quantities and delivery dates thereof, or may request to cancel all or part of this order, however, no such requested modification or cancellation shall become part of the contract between Buyer and Seller unless accepted by Seller in a written amendment to this Agreement. Acceptance of any such requested modification or cancellation shall be at Seller's discretion, and shall be upon such terms and conditions as Seller may require.

7. **Special Tooling:** A tooling charge may be imposed for any special tooling, including without limitation, dies, fixtures, molds and patterns, acquired to manufacture items sold pursuant to this contract. Such special tooling shall be and remain Seller's property notwithstanding payment of any charges therefor by Buyer. In no event will Buyer acquire any interest in apparatus belonging to Seller which is utilized in the manufacture of the items sold hereunder, even if such apparatus has been specially converted or adapted for such manufacture and notwithstanding any charges paid by Buyer therefor. Unless otherwise agreed, Seller shall have the right to alter, discard or otherwise dispose of any special tooling or other property in its sole discretion at any time.

8. **Buyer's Property:** Any designs, tools, patterns, materials, drawings, confidential information or equipment furnished by Buyer or any other items which become Buyer's property, may be considered obsolete and may be destroyed by Seller after two (2) consecutive years have elapsed without Buyer placing an order for the items which are manufactured using such property. Seller shall not be responsible for any loss or damage to such property while it is in Seller's possession or control.

9. **Taxes:** Unless otherwise indicated on the face hereof, all prices and charges are exclusive of excise, sales, use, property, occupational or like taxes which may be imposed by any taxing authority upon the manufacture, sale or delivery of the items sold hereunder. If any such taxes must be paid by Seller or if Seller is liable for the collection of such tax, the amount thereof shall be in addition to the amounts for the items sold. Buyer agrees to pay all such taxes or to reimburse Seller therefore upon receipt of its invoice. If Buyer claims exemption from any sales, use or other tax imposed by any taxing authority, Buyer shall save Seller harmless from and against any such tax, together with any interest or penalties thereon which may be assessed if the items are held to be taxable.

10. **Indemnity For Infringement of Intellectual Property Rights:** Seller shall have no liability for infringement of any patents, trademarks, copyrights, trade dress, trade secrets or similar rights except as provided in this Part 10. Seller will defend and indemnify Buyer against allegations of infringement of U.S. patents, U.S. trademarks, copyrights, trade dress and trade secrets (hereinafter "Intellectual Property Rights"). Seller will defend at its expense and will pay the cost of any settlement or damages awarded in an action brought against Buyer based on an allegation that an item sold pursuant to this contract infringes the Intellectual Property Rights of a third party. Seller's obligation to defend and indemnify Buyer is contingent on Buyer notifying Seller within ten (10) days after Buyer becomes aware of such allegations of infringement, and Seller having sole control over the defense of any allegations or actions including all negotiations for settlement or compromise. If an item sold hereunder is subject to a claim that it infringes the Intellectual Property Rights of a third party, Seller may, at its sole expense and option, procure for Buyer the right to continue using said item, replace or modify said item so as to make it non-infringing, or offer to accept return of said item and return the purchase price less a reasonable allowance for depreciation. Notwithstanding the foregoing, Seller shall have no liability for claims of infringement based on information provided by Buyer, or directed to items delivered hereunder for which the designs are specified in whole or in part by Buyer, or infringements resulting from the modification, combination or use in a system of any item sold hereunder. The foregoing provisions of this Part 10 shall constitute Seller's sole and exclusive liability and Buyer's sole and exclusive remedy for infringement of Intellectual Property Rights. If claim is based on information provided by Buyer or if the design for an item delivered hereunder is specified in whole or in part by Buyer, Buyer shall defend and indemnify Seller for all costs, expenses or judgments resulting from any claim that such item infringes any patent, trademark, copyright, trade dress, trade secret or any similar right.

11. **Force Majeure:** Seller does not assume the risk of and shall not be liable for delay or failure to perform any of Seller's obligations by reason of circumstances beyond the reasonable control of Seller (hereinafter "Events of Force Majeure"). Events of Force Majeure shall include without limitation, accidents, act of God, strikes or labor disputes, acts, laws, rules or regulations of any government or government agency, fires, floods, delays or failures in delivery of carriers or suppliers, shortages of materials and any other cause beyond Seller's control.

12. **Entire Agreement/Governing Law:** The terms and conditions set forth herein, together with any amendments, modifications and any different terms or conditions expressly accepted by Seller in writing, shall constitute the entire Agreement concerning the items sold, and there are no oral or other representations or agreements which pertain thereto. This Agreement shall be governed in all respects by the law of the Province of Quebec, Canada. No actions arising out of the sale of the items sold hereunder or this Agreement may be brought by either party more than two (2) years after the cause of the action accrues.



# STARCYL CYLINDERS

**STARCYL CYLINDERS**  
SPACE-SAVER AIR CYLINDERS

SINGLE OR MULTI-STAGE

THE ONLY CYLINDER UPGRADABLE!

**STAR 1 SERIES**

Not Enough Force  
Don't Change The Design  
Add A Stage!

STAR1 - Multistage Upgradable air cylinders

**STARCYL CYLINDERS**  
SPACE-SAVER

**STAR2 SERIES**

NFPA STYLE MOUNT

- Bore size from 1 1/2" to 10"
- Stroke up to 40"
- Save Space up to 35%
- 200 PSI AIR, OIL
- Two-Year Warranty
- Economic design

STAR2 - NFPA style Mount spacesaver air cylinders

**STARCYL AIR CYLINDERS**

...To boldly go where no cylinder has gone before ...

**STAR3 SERIES**  
WWW.STARCYL.COM

- NFPA, interchangeable
- Heavy Duty Air Cylinders
- Flush Mount available
- 11 Bore sizes From 1.5" through 12"
- Stroke available for any practical length
- 18 standard Mounting Styles
- Adjustable Air Cushion Standard
- 20 Year Warranty
- Two Year Warranty
- Economic Design

STAR3 - Heavy Duty NFPA interchangeable air cylinders Aluminum construction

**STARCYL AIR CYLINDERS**  
MULTI-STAGES

**M3 SERIES**

MULTI-STAGES NFPA STYLE MOUNT  
HEAVY DUTY - HIGH FLOW

NOMINAL PRESSURE - AIR 230 PSI  
STANDARD BORE SIZES 1.5" THROUGH 10"  
STROKE UP TO 42"

NFPA STYLE MOUNT  
TWO YEAR WARRANTY

M3 - Heavy Duty NFPA Multi-stages air cylinders High Flow

**STARCYL CYLINDERS**  
MEDIUM DUTY HYDRAULICS

**STAR5 SERIES**

MEDIUM DUTY SERVICES  
INDUSTRIAL TIE ROD CONSTRUCTION

STANDARD BORE SIZES 1.5" THROUGH 6"  
PISTON ROD DIAMETERS 5/8" THROUGH 5/4"

20 STANDARD MOUNTING STYLES  
STARRITE™ AVAILABLE ON EVERY STEEL PARTS

STAR4 - Heavy Duty NFPA interchangeable air cylinders. Steel

STAR5 - Medium Duty NFPA interchangeable Hydraulic cylinders

**STARCYL CYLINDERS**  
HEAVY DUTY Hydraulic Cylinders

**STAR6 SERIES**

HEAVY DUTY SERVICE  
INDUSTRIAL TIE ROD CONSTRUCTION

NOMINAL PRESSURE - 3000 PSI

STANDARD BORE SIZES 1.5" THROUGH 6"  
PISTON ROD DIAMETERS 5/8" THROUGH 5/4"

18 STANDARD MOUNTING STYLES  
STARRITE™ AVAILABLE ON ALL STEEL PARTS

STAR6 - Heavy Duty NFPA interchangeable Hydraulic cylinders, 3000 psi

**STARCYL AIR CYLINDERS**  
NFPA ROD LOCK CYLINDER

**ST3RL option**

FEATURES	BENEFITS
No Rod Displacement on Engagement	Maintains Accurate Positioning
Large Clamping Surface	Consistent Clamping Force
IP67 Rated Seals with NEMA 4X	Suitable for Wash-Down Areas
Fast Response Time	High Cycle Basic Accuracy
Extremely Low Backlash	Precision Holding
Spring Preload Units	Wide Load During Power/Pressure Loss
Rated for 2,750,000 Cycles	Long Maintenance Free Life
4 bar (60 psid) Release Pressure	Compact Unit, Easy Integration
	Broad Application

ST3RL - NFPA Rod Lock for STAR3 air cylinders

**STARCYL AIR CYLINDERS**  
SPACE ONE

Space. The Final Frontier ...

**Space Saver Air Cylinders**

So - Space One Series Spacesaver air cylinder

**WWW.STARCYL.COM**

YOUR STARCYL DISTRIBUTOR:

**STARCYL CYLINDERS**  
**877-STARCYL**

FAX: (630) 282-7142

IN CANADA: PH: 450-688-0505 - FAX 514-221-3798

**STM-MAY10**